



Update of QUALICOAT Specifications 2024

Update Sheet No. 01

applicable from 01.07.2024

Subject: Appendix A6 - Genoa (Outdoor Exposure)

Proposal / Requests: Alignment of the outdoor exposure conditions in QUALICOAT Specifications with EN 12206.

QUALICOAT Resolution:

Resolution No. 24/TC 2023.05.16

The TC tasked the Aluminium & Label Extension WG to prepare an update sheet for the approval of chemical pretreatments adopting the interim approval after 2 years and final approval after five years of outdoor exposure according to EN 12206-1.

Resolution No. 1/TC 2024.05.16

The TC approved the following update sheets with implementation date 1st July 2024:

1. SPEC 2024-US01 - Appendix A6 - Genoa (Outdoor Exposure)

Amendment to the Specifications:

New statements in Appendix A6, section 4, 5, 7, and 8

Author: QCT Specifications WG
Pascale Bellot

Document Code: SPEC 2024 – US01

QQM Section: 7.8.2

Date Approved: 17.05.2024

Approved by: Executive Committee

Valid from: 01.07.2024

Version: 01

No. of Pages: 4

A6 – Approval of chemical pretreatments

[...]

4. QUALICOAT TESTING LABORATORIES AND GENOA OUTDOOR EXPOSURE

Before a provisional approval is granted for a new pretreatment system, the laboratory in charge shall carry out the testing programme specified in the following section with conformity to QUALICOAT Specifications. Corrosion tests (including wet adhesion) shall also be performed by a second laboratory under the responsibility of the laboratory in charge.

On basis of positive results of outdoor exposure (location Genoa, Italy) an interim approval is granted after 2 years of exposure time and final approval after 5 years.

~~For renewal of an approval, the full testing programme shall be carried out only by the laboratory in charge.~~

For renewal procedure see section 8 of this appendix.

5. TESTING PROGRAMME

Approval is based on the following testing programme to ensure conformity with the requirements prescribed by QUALICOAT.

a) PANEL PREPARATION

The number of panels is prescribed by the QUALICOAT document Procedure of Sampling (see Appendix A2). ~~For every corrosion test, six extruded samples shall be evaluated (three samples in each of the two laboratories involved).~~ Special attention shall be paid to the preparation of samples. The final results of corrosion and exposure tests depend not only on the treatment but also on the aluminium composition and the reaction between the aluminium surface and chemical products.

The chemical manufacturers shall indicate the complete pretreatment cycle to be used (degreasing etc.), and the laboratory responsible for preparing the samples shall strictly follow these instructions.

Products intended for dual use need to be tested both ways. This implies that all tests must be done in duplicate, namely once with and once without the rinse pretreatment step.

The samples may be prepared:

- either in the QUALICOAT approved laboratory under the supervision of a representative of the applicant company;
- or in the laboratory of the chemical manufacturer under the supervision of a representative of the laboratory in charge.

[...]

c) OUTDOOR EXPOSURE

- **Exposure site**
 - 2 years in Genoa starting in September for interim approval
 - 5 years in Genoa starting in September for final approval
- **Number of panels**
 - All tests shall be made in triplicate.

Fig. 1 Scratches for outdoor exposure
(panel dimensions: length 200 mm, width 70 – 100 mm)

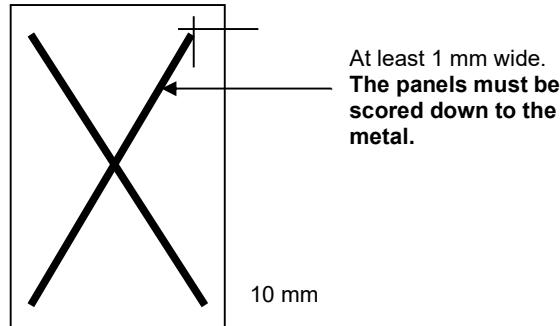

Evaluation of exposure test results

After 2 and 5 years of exposure, a **final** evaluation shall be made, applying the following criteria:

POSITIVE	0 or 1 unsatisfactory panel
NEGATIVE	2 or more unsatisfactory panels

Evaluation of test panels shall be according to the requirements of [§2.10](#).

[...]

7. GRANTING OF AN APPROVAL

If **all** the results meet the requirements, QUALICOAT shall issue a certificate which will be automatically reissued every year for a validity period of **three** one years as follows:

Provisional approval	after laboratory tests
Interim approval	after 2 years of outdoor exposure
Final approval	after 5 years of outdoor exposure

The approval status is part of the approval document and is displayed in the approval list.

~~After the exposure tests, the working group shall evaluate the results and take a decision on confirmation of the approval. The manufacturer shall be informed of the results and decisions.~~

8. RENEWAL OF PRETREATMENT SYSTEM APPROVALS

a) Renewing pretreatment system approvals

Systems with less than 10 coating lines in operation

Approvals shall be renewed every **three** five years, with the full laboratory testing programme (only for systems with less than 10 coating lines in operation) including five years of outdoor exposure (see section 5 of this Appendix) carried out by one laboratory. ~~Once a system has been approved for six consecutive years, the renewal interval shall be extended to five years.~~

Systems with 10 or more coating lines in operation

Approvals shall be renewed every five years, only with five years of outdoor exposure according to section 5 of this Appendix (without the laboratory testing programme) carried out by one laboratory.

The renewal process shall begin after the granting of the final approval. The test panels shall be sent to the laboratory for testing no later than end of March in the following year.

The remaining renewal processes shall follow the same time schedule.

If an approved system identified by a single approval number is manufactured at different production sites of the same company, the full testing programme (including the exposure test) shall be carried out for the main production site and/or technical service centre. At the other production sites indicated by the chemical manufacturer, the approved pretreatment system shall be checked only with AASS and FFC tests, specifically by sending coated samples that have been treated with the products manufactured at all other production sites to the same laboratory that is also responsible for the main production site. The respective provenance shall be clearly stated.

~~An approval shall be renewed if the results of the laboratory and exposure tests conform to the Specifications. The certificate shall be issued every year.~~

b) Repetition of unsatisfactory ~~laboratory~~ tests

If the laboratory test results are unsatisfactory, all ~~corrosion~~ laboratory tests shall be repeated ~~in two laboratories. Renewal shall be confirmed if the results are satisfactory in both laboratories. If the results are unsatisfactory in one of the two laboratories~~ If the repeated laboratory tests again produce unsatisfactory results, the approval shall then be cancelled. If the result of outdoor exposure is unsatisfactory, the approval shall then be cancelled.

[...]